

Nauticam
innovation underwater

NA - 502

Instruction manual



FORWARD

Thank you for your purchase of a NAUTICAM housing.

At NAUTICAM, we pride ourselves in the ability to recognise the requirements of professional as well as amateur underwater photographers and fulfill them through the innovative designs of our products. We strive to achieve a high level of user-friendliness by allowing stress-free installation and easy operation of all important functions of the camera.

Each housing is individually inspected and water pressure tested to ensure optimum quality.

Please read this manual carefully before using the housing, this will maximise its performance as well as its lifetime.

TABLE OF CONTENTS

Warranty	4
Package Contents	6
Precautions	7
Specifications	9
Identification of Parts	10
Opening and Locking the Housing	12
Preparation of the Housing	14
Installing the Monitor	20
Connecting to the Camera Housing	22
Care and Maintenance	31
Optional Accessories	32

WARRANTY

All NAUTICAM Products are warranted against any material and manufacturing defects for two years from the date of purchase for consumer use. Please fill in the warranty cards shipped with our housings and viewfinders at the time of sale and return them to your point of purchase within a month. If we do not receive the completed warranty card for a particular product, the warranty period would be assumed to begin from the day that the product is shipped from our facility. This warranty only applies to products purchased from authorised NAUTICAM dealers and does not extend beyond the original retail purchaser.

To return your product for service, please contact your regional authorized service centre(s). Please note that this warranty only applies when the product is purchased in the territory where the service centre is located.

NAUTICAM accepts no liability for any damage to and defects in the housing caused by improper use and/or poor maintenance; it is the responsibility of the owner to carefully follow the instructions in our manuals.



NAUTICAM does not hold responsibility for damage, of any nature, to any equipment used with and/or placed within our products.

NAUTICAM accepts no liability for any loss of captured images or the inability to capture images even if it is due to the malfunctioning of our products.

Unauthorised modifications and/or repairs of our products will automatically invalidate the warranty.

PACKAGE CONTENTS

- NA-502 Housing
- M16 Vacuum Valve (pre-installed)
- Hand pump for vacuum valve
- Spanner for vacuum valve
- Spare silicone rubber main O-ring
- O-ring remover
- CR2032 battery
- Lubricant
- Set of Allen keys
- Instruction manual

For 17906 NA-502H

1. HDMI (A-D) cable in 750mm length (pre-installed)
2. M16 HDMI bulkhead
3. HDMI (D-C) cable in 130mm length
4. HDMI (D-C) cable in 190mm length
5. HDMI (D-D) cable in 200mm length

For 17907 NA-502S

1. SDI cable in 0.75m length (pre-installed)
2. M16 SDI Bulkhead
3. SDI cable in 0.3m length

PRECAUTIONS

- A water-tight test without the monitor inside the housing is highly recommended when using the system for the first time and after the changing of port and O-ring(s).
- Do not use lubricants from other brands with the silicone rubber O-ring on this housing, only use the lubricant provided by NAUTICAM.
- Discontinue use immediately should you notice any leakage.
- Store the housing in a robust, shock-proof container during transportation; avoid transporting with any equipment, such as a camera, inside the housing.
- When travelling by air, do not close the housing as this may lead to a pressure difference between the atmosphere and inside the housing.
- Care must be taken when opening the housing, as pressure may build up inside the housing which increases the opening force.

- Do not open the product in a wet or sandy environment. Protect the interior from moisture and debris in order to prevent malfunction or leakage.
- Do not store the product in an environment of high humidity.
- Do not leave the housing and the monitor in direct sunlight for prolonged periods.
- Keep out of reach of children, failure to do so could result in injury.
- Defective products should be shipped to our distributors for service, unauthorized disassembling and/or modifications could result in malfunction or leakage.

SPECIFICATIONS

Construction	Housing body:	Aluminium alloy
	Surface treatment:	Hard anodised
	Display window:	Abrasion resistant polycarbonate
Dimensions	Width:	222mm
	Height:	118mm
	Depth:	67mm
Weight	Approx. 1.39kg	
Buoyancy		
Depth rating	100 metres	

IDENTIFICATION OF PARTS

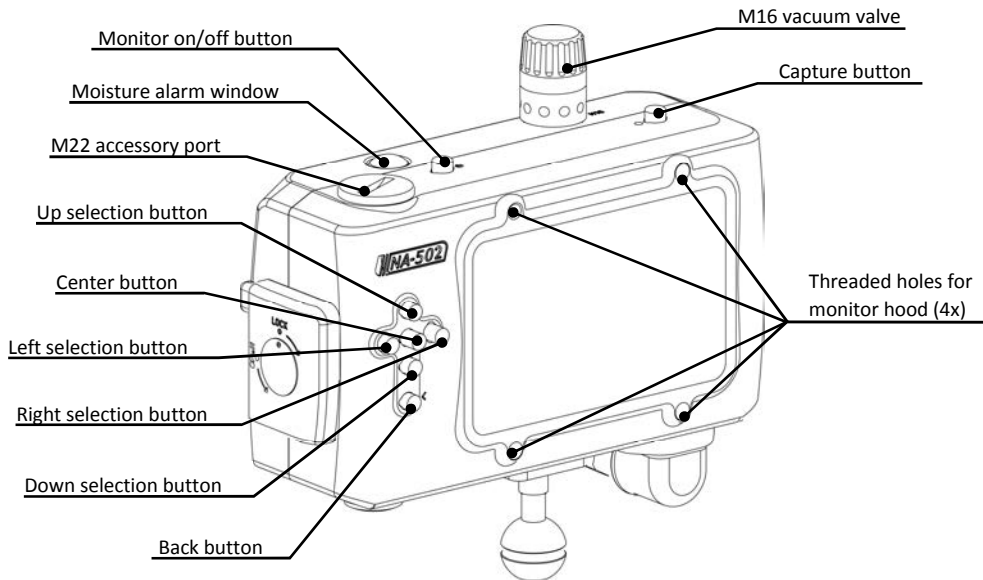

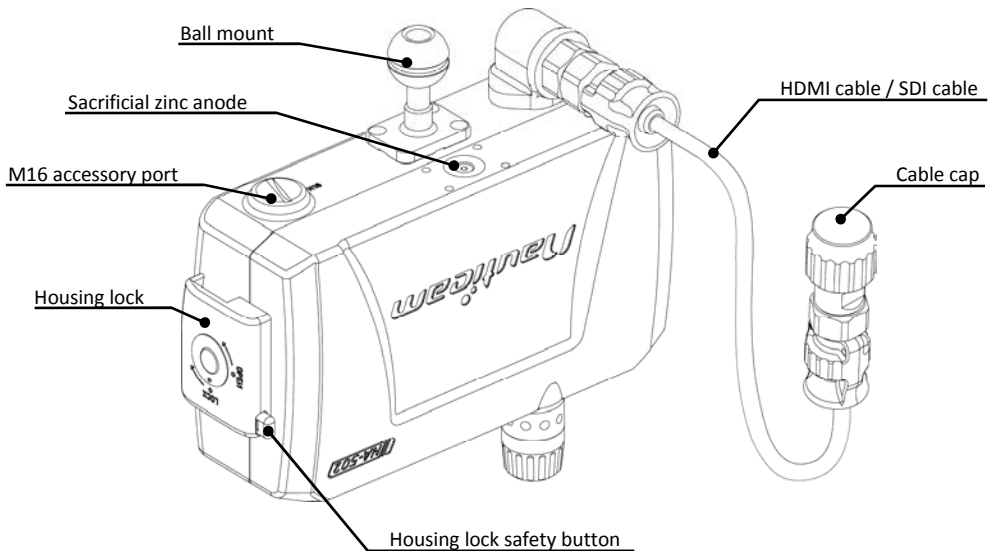

OPENING AND LOCKING THE HOUSING

To open the housing:

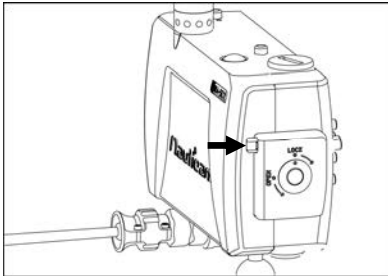

1. Press the housing lock safety button.

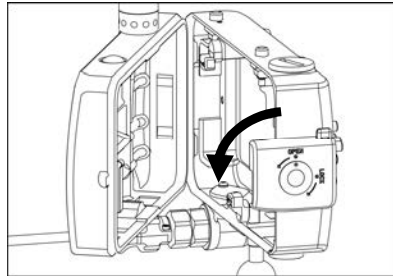

2. Turn the housing lock anti-clockwise for 270°, until the lock reaches the “Open” position as shown.

To lock the housing:

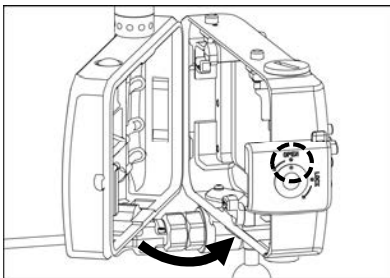

3. Close the housing while the housing lock is in the “Open” position.

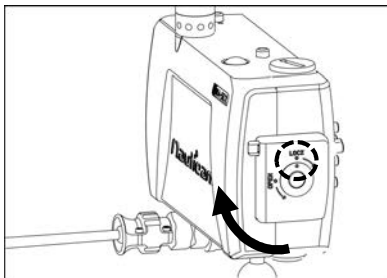

4. Turn the housing lock clockwise for 270°, until the lock reaches the “lock” position as shown. Confirm that the white indicator line on the safety button is visible.

PREPARATION OF THE HOUSING

1. After verifying that the main O-ring is in good condition, lightly coat it with the lubricant provided.
2. Make sure the O-ring groove located in the front part of the housing is free from any foreign material; the groove can be cleaned with the aid of a microfiber cloth.
3. Place the main O-ring into the groove, first at the corners, then the whole perimeter.

4. Setting up the moisture alarm:

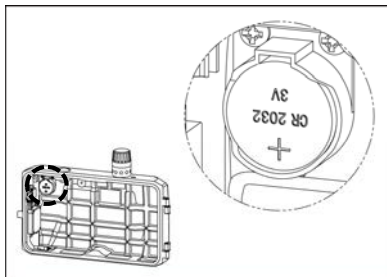

1. Install the CR2032 battery provided into the battery compartment on the circuit board inside the front part of the housing.

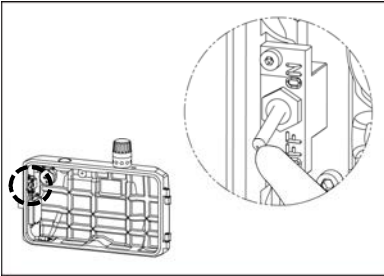

2. Switch the alarm on. The LED light will flash blue once and turn blue for five seconds indicating the battery is normal. Then it goes into flashing blue light standby mode.

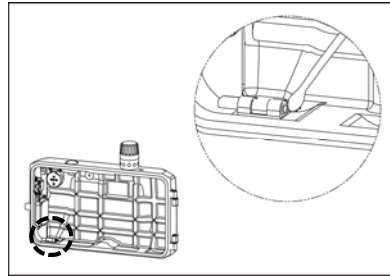

3. Test the alarm by connecting the two wires near the bottom of the housing with a damp cotton bud; the alarm should start giving out a repeating “beep” sound along with a flashing red light. The “beep” sound and the light should keep on going for 5 seconds after the removal of the damp cotton bud.

To build up vacuum:

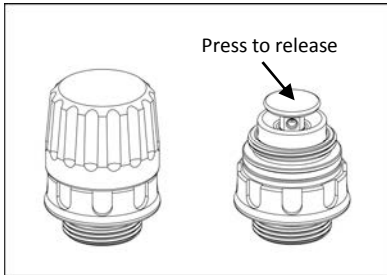

1. Remove the vacuum valve cap.
2. Connect the hand pump to the valve and pump several times until it reaches the target vacuum level.

3. After the target vacuum level is reached, i.e. steady green light.

Attention: After the target vacuum is reached, i.e. steady green light, attach the cap back to the vacuum valve.

4. It is recommended to leave the housing for at least 20mins to ensure it is sealed. If the LED light changes from steady green light to rapidly flashing yellow light, that means there is a leakage and please check every o-ring and conduct the vacuum test again.

Caution: Please DO NOT attempt to go over the designated vacuum level, i.e. stop as the pump is pumping when the LED turns green. Excessive vacuum level may lead to the malfunctioning of the camera and lens.

Attention: Although the vacuum indicator is designed to compensate for a certain amount of temperature variation, it is recommended to conduct the vacuum test in an environment where the temperature is stable.

5. Please ensure that the cap is attached back to the vacuum valve before going underwater.
6. Vacuum can be released by pushing the red release button.

LED status identification:

On start up:

<i>LED indicator</i>	<i>Status</i>
Flash "Blue" light once	Indicates a 2nd generation PCB
Steady "Blue" light	Battery is normal, goes into flashing "Blue" light standby mode after 5 seconds.
"Blue" and "Red" lights alternating	Battery low. Replace battery as soon as possible. Goes into standby mode after 5 seconds.
Steady "Red" light	Battery empty, replace battery.

After start up:

<i>LED indicator</i>	<i>Status</i>
Flashing "Blue" light	Standby mode. The moisture alarm is active, and the system is ready for vacuum indication whenever a vacuum is detected.
Flashing "Red" light with beeping sound	Moisture is detected.
Flashing "Yellow" light	Some vacuum is detected, target vacuum level is not reached.
Steady "Green" light	Target vacuum level is reached.
Rapidly flash "Yellow" light	Vacuum is dropping. (Will occur only after target vacuum level is reached)
Rapidly flashing "Red" light	Vacuum is totally lost. Circuit stalled until switched off. (Will occur only after target vacuum level is reached)

INSTALLING THE MONITOR

To install the monitor into to the housing:

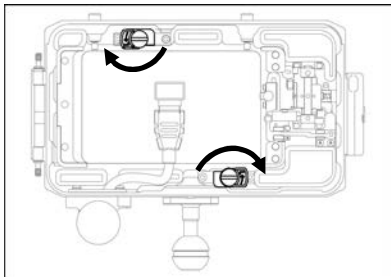

1. Turn the two locking levers in the direction as shown.

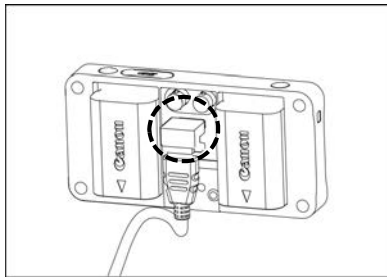

2. Connect the HDMI cable with "L" connector to the monitor's HDMI in socket as shown above or HD-SDI cable to the monitor's SDI out socket.

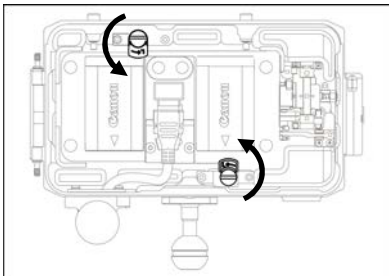

3. Place the monitor inside the housing and secure the monitor by turning the two locking levers towards the monitor as shown.

CONNECTING TO THE CAMERA HOUSING

For installing the standard HDMI bulkhead with M16 thread or M16 SDI bulkhead:

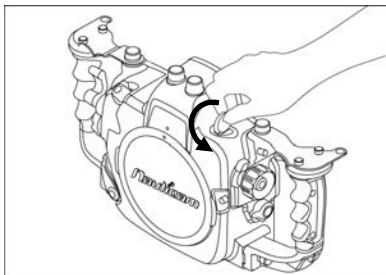

3. Unscrew the M16 plug from the threaded hole with a coin.

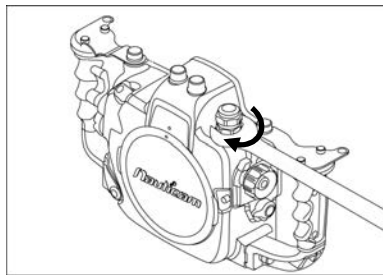

2. Tighten the HDMI or HD-SDI bulkhead with a spanner.

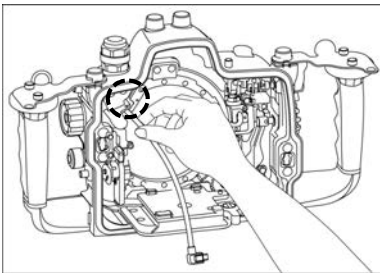

3. Connect the HDMI /HD-SDI cable to the HDMI /HD-SDI bulkhead.

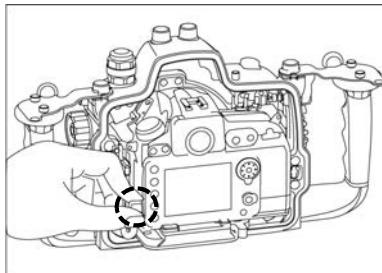

4. Connect the HDMI / HD-SDI cable to the camera's HDMI / HD-SDI socket.

For installing the custom HDMI bulkhead to use with extension:

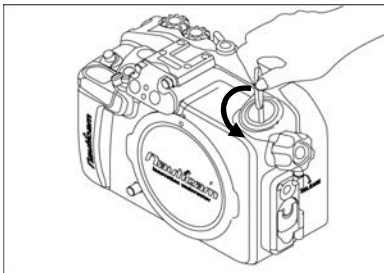

1. Unscrew the M16 plug from the accessory port with a coin.



2. Tighten the socket extension to the camera housing with a spanner.

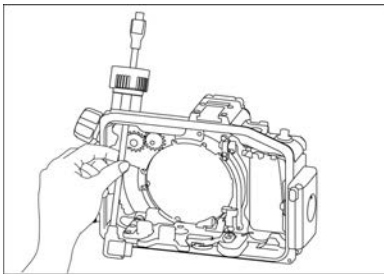

3. Insert the HDMI cable through the threaded hole from inside of the housing.

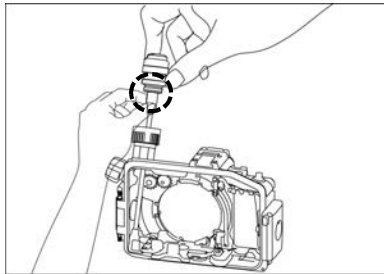

4. Connect the HDMI cable to the HDMI bulkhead.

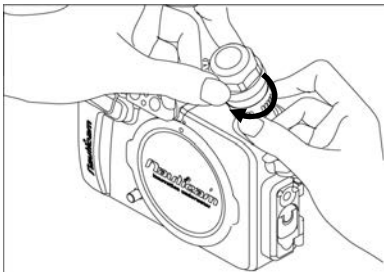

5. Tighten the HDMI bulkhead by turning the threaded ring on the socket extension.

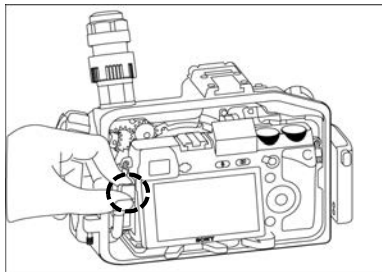

6. Connect the HDMI cable to the camera's HDMI connector.

To connect the monitor housing to HDMI / SDI bulkhead:

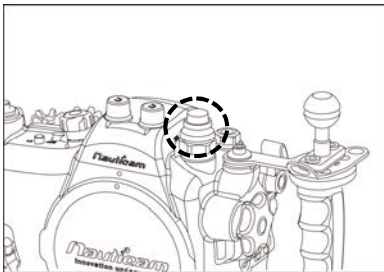

1. Unscrew the cap off the HDMI /SDI bulkhead.

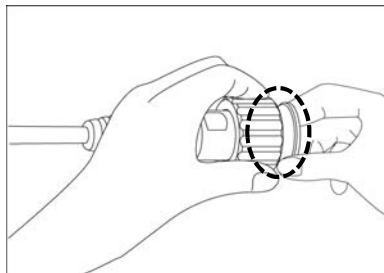

2. Unscrew the cap off the HDMI /HD-SDI cable.

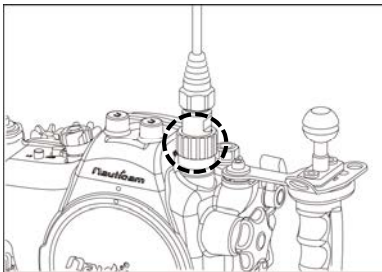

3. Align and plug the HDMI /HD-SDI cable in the HDMI /HD-SDI bulkhead. Tighten the connection by turning the threaded ring on the HDMI /HD-SDI cable.

OPTIONAL: SDI OUTPUT TO SURFACE MONITOR

SmallHD 502 features SDI Passthrough, and HDMI to HD-SDI cross convert, which allow a video signal to be sent topside to a director's monitor.

Note: Extra HD-SDI bulkhead (#25058) and cables (#25060 for internal connection, #25064 15m HD-SDI Surface Feed Cable or #25065 45m HD-SDI Surface Feed Cable) are required.

Please follow below instruction for setting:

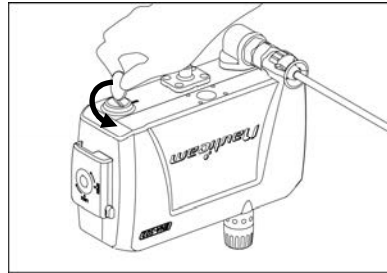

1. Unscrew the M16 plug from the accessory port as shown with a coin.

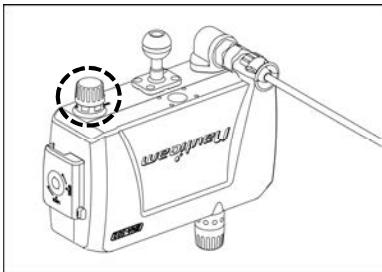

2. Tighten the HD-SDI bulkhead with a spanner.

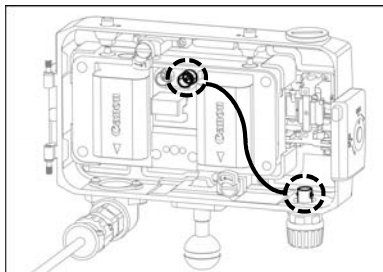

3. Connect the HD-SDI cable to the HD-SDI bulkhead and to the monitor SDI-out socket.

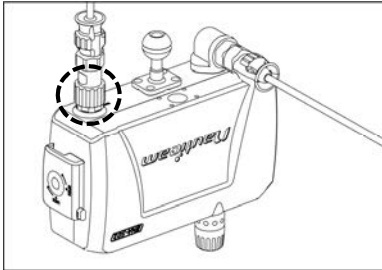

4. Remove the cap of both HD-SDI bulkhead and HD-SDI Surface Feed Cable then plug the cable to the bulkhead.
5. Tighten the connection by turning the threaded ring on the HD-SDI cable.

CARE AND MAINTENANCE

- Soak the housing system in fresh water after each salt water use, during which all control buttons/knobs should be operated a few times to avoid the accumulation of salt residue; wipe the housing with a towel before opening.
- Carefully press the housing lock safety button for a few times to avoid the accumulation of salt residue.
- After each day of diving, it is advisable to have the main O-ring in the front part of the housing removed from its groove with the O-ring remover and inspected for damage. Also check that the O-ring retains its original circular shape; never stretch the O-ring excessively or remove it with a sharp object. The O-ring groove should be cleaned to ensure it is free from any salt deposit or foreign material; lightly coat the O-ring with the provided lubricant before reinstalling it in the groove. A damaged O-ring should be discarded immediately and replaced only with one that is provided by NAUTICAM.
- Replace the main O-ring annually. It is recommended that you ship the housing to our distributor for a complete overhaul every year or after every 200 dives.

OPTIONAL ACCESSORIES



P.N. 17916
Monitor hood for NA-502



P.N. 25058
M16 SDI bulkhead

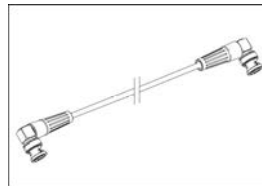

P.N. 25060
SDI cable in 0.4m length



P.N. 25064 / 25065
SDI surface monitor cable in
15m/45m length (for
connection from SDI Bulkhead
to Surface Monitor on land)



P.N. 25059
SDI cable extension adaptor



P.N. 25063
SDI cable in 30m length
(for connection between
SDI Bulkheads)



NAUTICAM International Limited

**Rm2203, CCT Telecom Building,
11 Wo Shing Street, Fotan,
HONG KONG**

**Web: www.nauticam.com
E-mail: enquiry@nauticam.com
Tel: +852 2690 2711
Fax: +852 2690 9778**